

FLOW CONTROLS

FC10-20 Flow Control

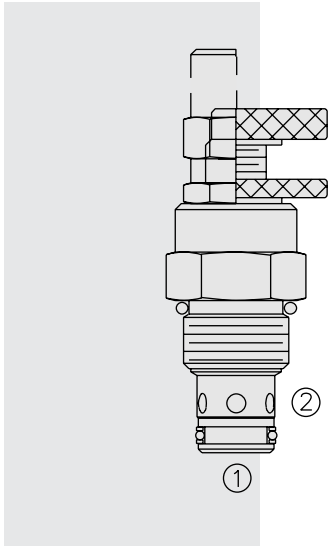

DESCRIPTION

A screw-in, cartridge-style, variable orifice, hydraulic flow control valve with reverse flow check.

OPERATION

The **FC10-20** increases its orifice value from fully closed to fully open with counterclockwise adjustment rotation.

FEATURES

- Adjustments cannot be backed out of the valve.
- Desired settings may be locked down.
- Hardened parts for long life.
- Industry common cavity.
- Aluminum knob option.
- Positive shut-off.
- Linear adjustment.

RATINGS

Operating Pressure: 240 bar (3500 psi)

Flow: 45 lpm (12 gpm) nominal at 7 bar (100 psi) at full open 3.0 turns

Internal Leakage: 0.50 cc/minute (10 drops/minute) max. at shut-off

Adjustment Torque Required: 0.34 Nm (3 inch-pounds) at 7 bar (100 psi);
4.50 Nm (40 inch-pounds) at 207 bar (3000 psi)

Temperature: -40 to 120°C

Filtration: See page 9.010.1

Fluids: Mineral-based or synthetics with lubricating properties at viscosities of
7.4 to 420 cSt (50 to 2000 sus); See Temperature and Oil Viscosity, page 9.060.1

Installation: No restrictions; See page 9.020.1

Cavity: VC10-2; See page 9.110.1

Cavity Tool: CT10-2XX; See page 8.600.1

Seal Kit: SK10-2X-M; See page 8.650.1

SYMBOLS

USASI:

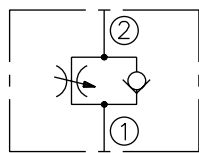

ISO:

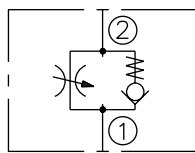

PERFORMANCE (Cartridge Only)

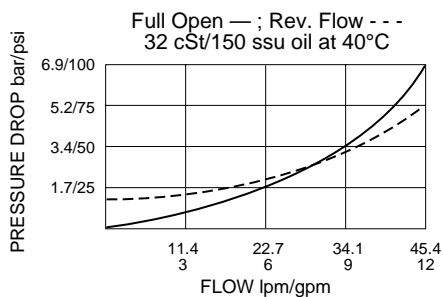

DIMENSIONS

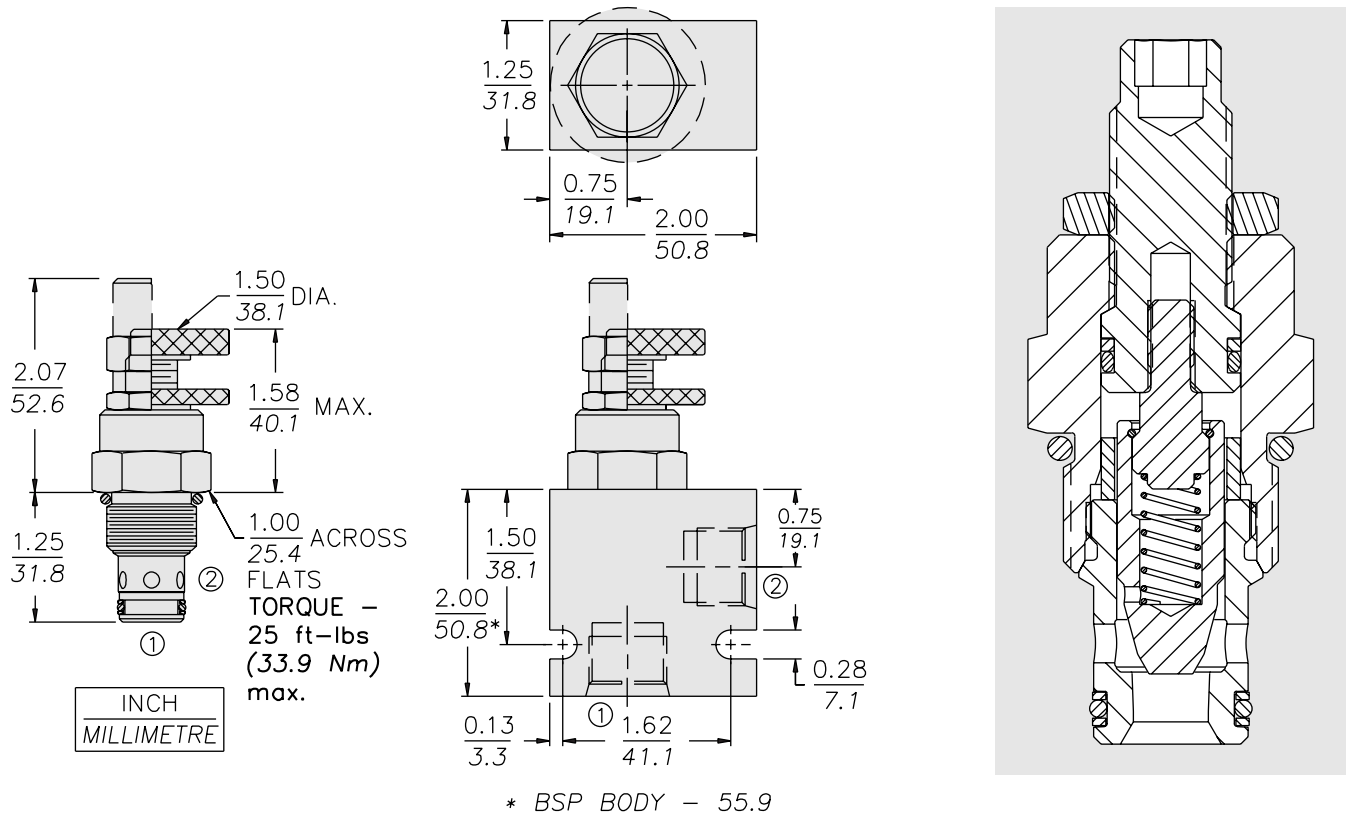

MATERIALS

Cartridge: Weight: 0.17 kg. (0.37 lbs.)
 Steel with hardened work surfaces.
 Zinc-plated exposed surfaces.
 Buna N O-rings and polyester elastomer back-ups standard.
 Anodized aluminum knobs.

Standard Ported Body: Weight: 0.16 kg. (0.35 lbs.)
 Anodized high-strength 6061 T6 aluminum alloy, rated to 207 bar (3000 psi). Ductile iron bodies available; dimensions may differ. See page 8.010.1.

TO ORDER

FC10-20		-	-
Adjustment Option			Seals
1/4 in. Hex Allen Head	A		N Buna N (Std.)
1-1/2 in. Dia. Alum. Knob	B		V Fluorocarbon
Option A with Cover Cap	C		
Top Knob with Lock Nut	D		
Top Knob Only	E		
			Porting
			0 Cartridge Only
			6T SAE 6
			8T SAE 8
			2B 1/4 in. BSP*
			3B 3/8 in. BSP*
			4B 1/2 in. BSP*

*BSP Body; U.K. Mfr. Only