

FR10-33 Flow Regulator, Pressure Compensated

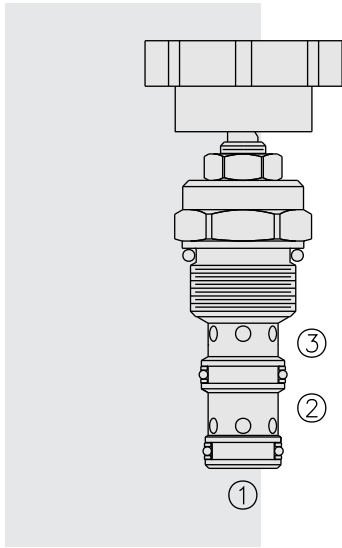

DESCRIPTION

A screw-in, cartridge-style, adjustable orifice, pressure-compensated, manually-operated, bypass-type hydraulic flow regulating valve. It can be used as a priority-type flow regulator or a restrictive-type 2-way flow regulator when the bypass port (port 2) is blocked.

OPERATION

The **FR10-33** maintains a constant flow rate from 3 regardless of load pressure changes in the system downstream of 3, or in the bypass leg at 2. Reverse flow (3 to 1) bypasses the control orifice.

The regulated flow increases from closed to fully open, with counter-clockwise rotation of the knob.

Note: When used as a bypass flow control in applications where the priority flow port will be blocked by external valving, bypass pressure drop will increase unless a small amount of leakage is provided for the priority port. Consult factory.

FEATURES

- Bypass port 2 may be fully pressurized.
- Fine low-torque adjustment.
- Hardened steel parts for long life.
- Quiet, modulated response.
- Industry common cavity.

RATINGS

Operating Pressure: 240 bar (3500 psi)

Flow Rate: 3-ported regulated flow: 0–13 lpm (0–3.5 gpm)
2-ported regulated flow: 0–12 lpm (0–3.2 gpm)

Note: For higher flow rates, see the FR10-39 valve (page 5.382.1)

Input Flow: 3-ported: 0–19 lpm (0–5 gpm) nominal; 0–26 lpm (0–7 gpm) max.

Internal Leakage: 33 cc/minute (2 cu. in./minute) at 207 bar (3000 psi)

Adjustment Torque Required: 1.7 Nm (15 inch-pounds) at 207 bar (3000 psi)

Temperature: -40 to 100°C (-40 to 212°F) with Buna N seals;
-26 to 204°C (-15 to 400°F) with fluorocarbon seals.

Filtration: See page 9.010.1

Fluids: Mineral-based or synthetics with lubricating properties at viscosities of 7.4 to 420 cSt (50 to 2000 sus); See Temperature and Oil Viscosity, page 9.060.1

Installation: No restrictions; See page 9.020.1

Cavity: VC10-3; See page 9.110.1

Cavity Tool: CT10-3XX; See page 8.600.1

Seal Kit: SK10-3X-MM; See page 8.650.1

Knob Kit: Part Number 6113160

ISO SYMBOLS

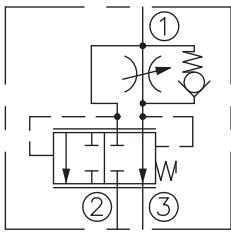

2-Ported:

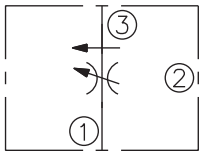

3-Ported:

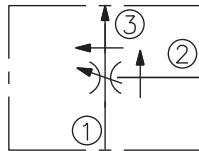

PERFORMANCE (Cartridge Only)

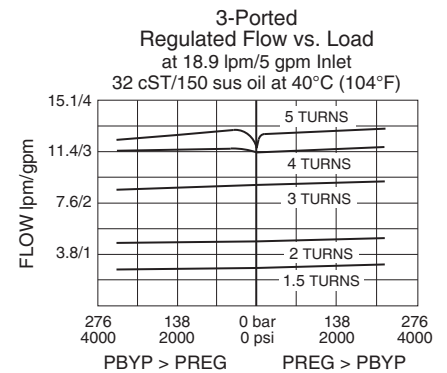
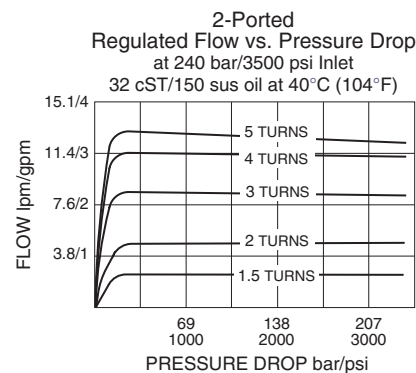
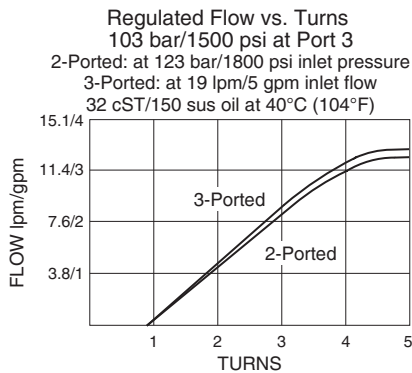

DIMENSIONS

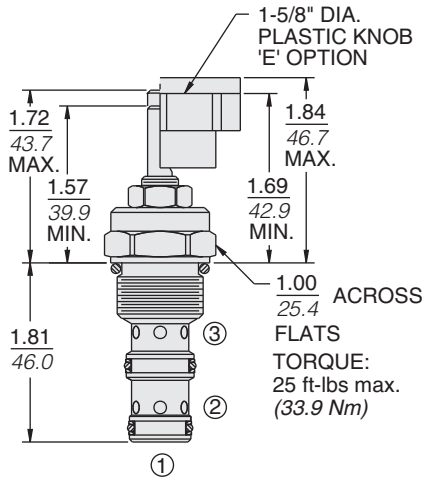
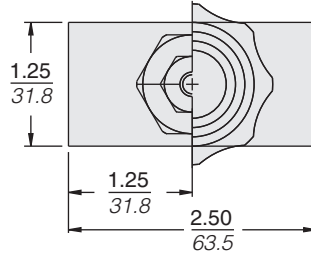
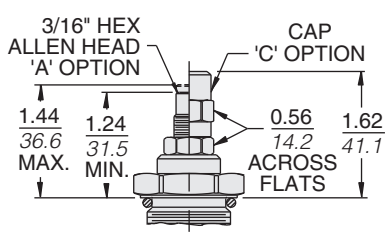

INCH
MILLIMETRE

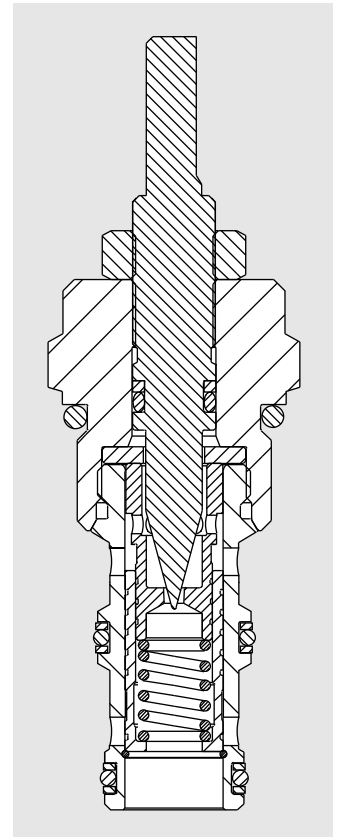
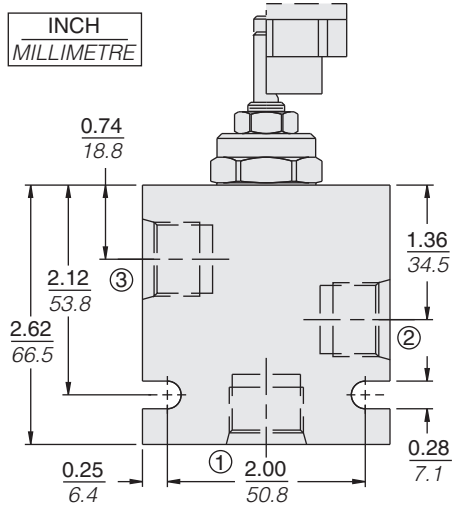

MATERIALS

Cartridge: Weight: 0.30 kg. (0.68 lbs.) Steel with hardened work surfaces. Zinc-plated exposed surfaces. Buna N O-rings and polyester elastomer back-ups standard.

Standard Ported Body: Weight: 0.36 kg. (0.80 lbs.) Anodized high-strength aluminum alloy, rated to 207 bar (3000 psi). Ductile iron bodies available; dimensions may differ. See page 8.010.1

TO ORDER

FR10-33

| | | | |
|--------------------------|-------|---------------|--------------------------|
| Adjustment Option | Blank | Seals | Flow Setting |
| Extended Shaft Only | A | Buna N (Std.) | (Blank) Factory Set at |
| 3/16" Hex Allen Head | C | Fluorocarbon | 1 to 2 gpm |
| Option 'A' w/Cover Cap | E | | Specify, for example: |
| Plastic Knob | | | Setting in lpm |
| | | | Specify, for example: |
| Porting | | | M1.0 1.0 lpm |
| Cartridge Only | 0 | | M5.0 5.0 lpm etc. |
| SAE 6 | 6T | | Setting in gpm |
| SAE 8 | 8T | | Specify, for example: |
| 1/4 in. BSP* | 2B | | 0.5 0.5 gpm |
| 3/8 in. BSP* | 3B | | 1.5 1.5 gpm etc. |

*BSP Body; U.K. Mfr. Only