

DIRECTIONAL VALVES

LS10-30 Load Shuttle, Ball-Type

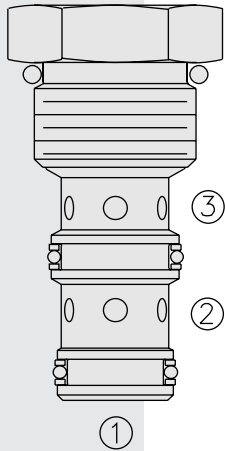

DESCRIPTION

A load-shuttling, screw-in, cartridge-style hydraulic check valve, for use in blocking circuits where a priority of flow/direction is given to a higher pressure circuit over a lower one.

OPERATION

The **LS10-30** will allow flow from the higher pressure ① or ③ port to the ② port. The valve is commonly used to direct oil from the pressure side of a bidirectional hydraulic motor to a pressure-released hydraulic brake.

FEATURES

- Rapid response to load direction changes.
- Industry common cavity.

RATINGS

Operating Pressure: 240 bar (3500 psi)

Proof Pressure: 390 bar (5700 psi)

Flow: See Performance Chart

Internal Leakage: 0.25 cc/minute (5 drops/minute) max. at 207 bar(3000 psi)

Temperature: -40 to 120°C with standard Buna seals

Filtration: See page 9.010.1

Fluids: Mineral-based or synthetics with lubricating properties at viscosities of 7.4 to 420 cSt (50 to 2000 sus); See Temperature and Oil Viscosity, page 9.060.1

Installation: No restrictions; See page 9.020.1

Cavity: VC10-3; See page 9.110.1

Cavity Tool: CT10-3XX; See page 8.600.1

Seal Kit: SK10-3X-MM; See page 8.650.1

SYMBOLS

USASI/ISO:

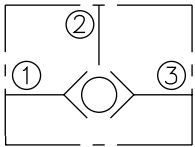

PERFORMANCE (Cartridge Only)

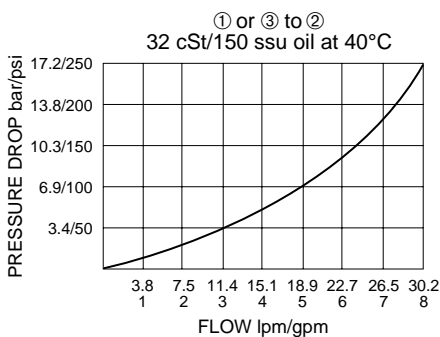

DIMENSIONS

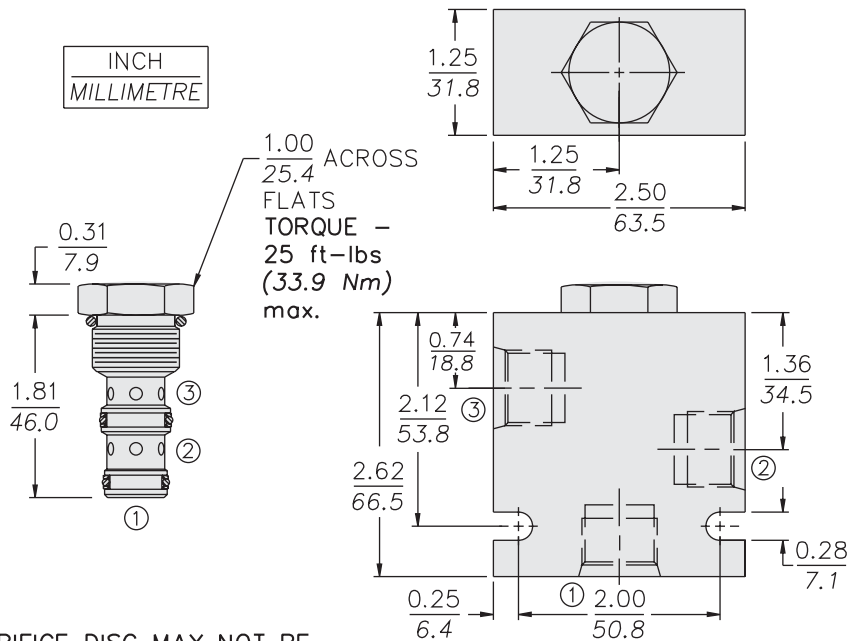

ORIFICE DISC MAY NOT BE USED WITH THIS PRODUCT.

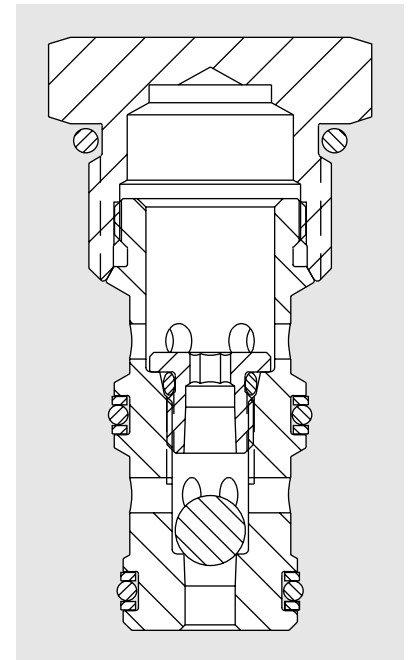

MATERIALS

Cartridge: Weight: 0.08 kg. (0.18 lbs.)
Steel with Zinc-plated exposed surfaces; Buna N O-rings and polyester elastomer back-ups standard.

Standard Ported Body: Weight: 0.36 kg. (0.80 lbs.) Anodized high-strength 6061 T6 aluminum alloy, rated to 207 bar (3000 psi). Ductile iron bodies available; dimensions may differ. See page 8.010.1

TO ORDER

LS10-30-		Seals	
Porting		N	Buna N (Std.)
Cartridge Only	0	V	Fluorocarbon
SAE 6	6T		
SAE 8	8T		
1/4 in. BSP*	2B		
3/8 in. BSP*	3B		
*BSP Body; U.K. Mfr. Only			