

NV10-21 Needle Valve with Positive Shut-Off

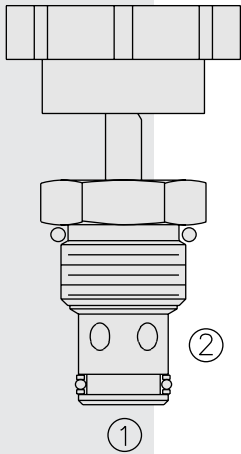

DESCRIPTION

A screw-in, cartridge-style, variable orifice, hydraulic flow restrictor valve. It is intended for applications requiring fine adjustment over multiple turns.

OPERATION

The **NV10-21** increases its orifice value from fully closed to fully open with adjustment rotation in the counterclockwise direction. Effective adjustment is linear to eight turns. Note: This is intended as a low-effort adjustment suitable for operation through linkage. It may be unsuitable in environments where vibration is present.

FEATURES

- Adjustment cannot be backed out of the valve.
- Hardened parts for long life.
- Industry common cavity.
- Fine/low effort adjustment.
- Positive shut-off.
- Linear adjustment.

RATINGS

Operating Pressure: 240 bar (3500 psi)

Flow: 57 lpm (15 gpm) nominal at 11 bar (160 psi) at full open 9 turns

Internal Leakage: 0.05 cc/minute (1 drop/minute) max. at shut-off

Adjustment Torque Required: 0.34 Nm (3 inch-pounds) at 7 bar (100 psi); 0.68 Nm (6 inch-pounds) at 207 bar (3000 psi)

Temperature: -40 to 120°C

Filtration: See page 9.010.1

Fluids: Mineral-based or synthetics with lubricating properties at viscosities of 7.4 to 420 cSt (50 to 2000 sus); See Temperature and Oil Viscosity, page 9.060.1

Installation: No restrictions; See page 9.020.1

Cavity: VC10-2; See page 9.110.1

Cavity Tool: CT10-2XX; See page 8.600.1

Seal Kit: SK10-2X-M; See page 8.650.1

SYMBOLS

USASI/ISO:

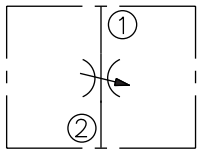

PERFORMANCE (Cartridge Only)

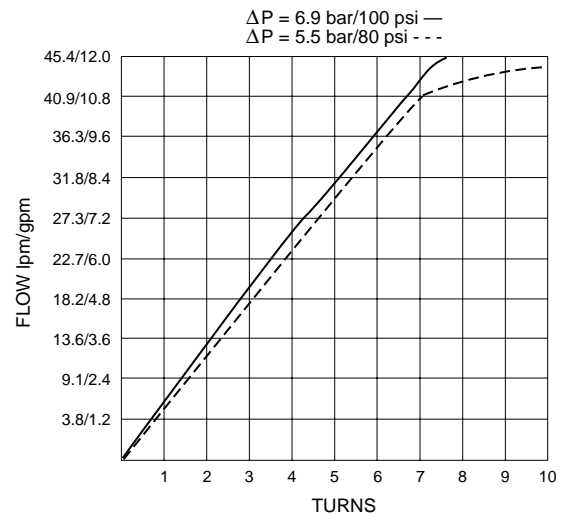
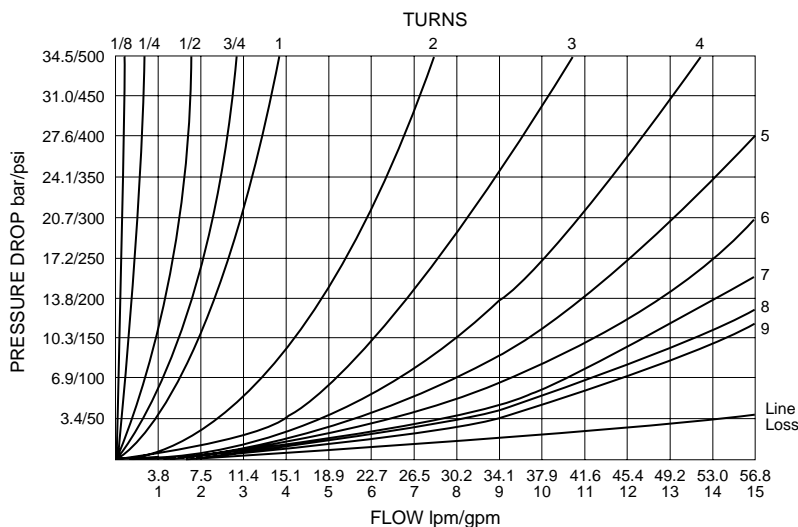

DIMENSIONS

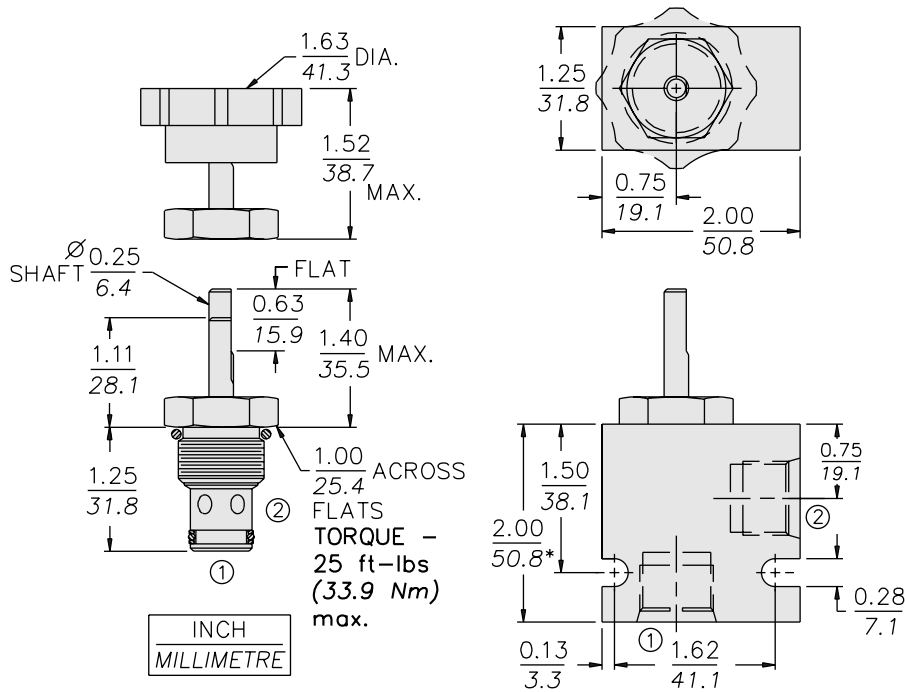

* BSP BODY - 55.9

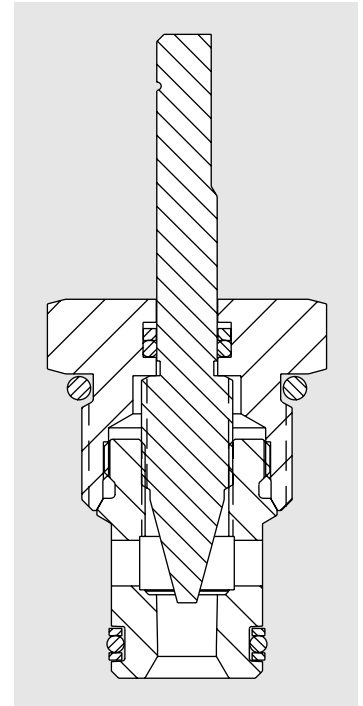

MATERIALS

Cartridge: Weight: 0.15 kg. (0.33 lbs.)
Steel with hardened work surfaces.
Zinc-plated exposed surfaces.
Buna N O-rings and polyester elastomer back-ups standard.
Plastic knob with metal insert.

Standard Ported Body: Weight:
0.16 kg. (0.35 lbs.) Anodized high-strength 6061 T6 aluminum alloy, rated to 207 bar (3000 psi) Ductile iron bodies available; dimensions may differ. See page 8.010.1

TO ORDER

