

PD10-40 Piloted 3-Way Spool, External Vent

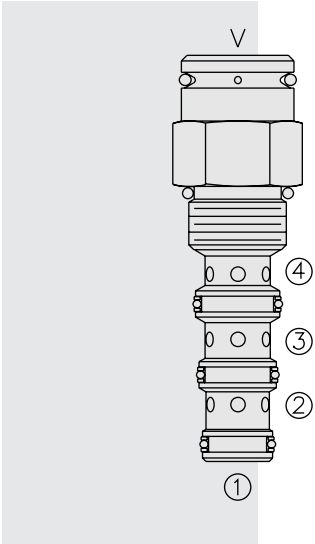

DESCRIPTION

A screw-in, cartridge-style, pilot-operated, spool-type, hydraulic directional valve for three-way circuits requiring remote pilot actuation.

OPERATION

In neutral (unpiloted), the **PD10-40** allows flow from ③ to ② bidirectionally, while flow is blocked at ④. V is a spring chamber vent-to-atmosphere, which is internally O-ring sealed from the cartridge flow paths.

On remote pilot signal at ①, the valve shifts to open from ③ to ④, while blocking flow at ②.

Because of the vented spring chamber, the cartridge may be fully pressurized at any port without affecting required pilot pressure.

FEATURES

- Hardened spool and cage for long life.
- Industry common cavity.

RATINGS

Operating Pressure: 240 bar (3500 psi)

Proof Pressure: 350 bar (5075 psi)

Flow: See Performance Chart

Internal Leakage: 82 cc/minute (5 cu. in./minute) max. at 207 bar (3000 psi)

Pilot Pressure Required:

To Spool Crossover: 7.6 bar (110 psi)

To Full Spool Shift: 8.6 bar (125 psi)

Oil Volume Required to Full Shift: 0.65 cc (0.04 cu. in.)

Temperature: -40 to 120°C with standard Buna seals

Filtration: See page 9.010.1

Fluids: Mineral-based or synthetics with lubricating properties at viscosities of 7.4 to 420 cSt (50 to 2000 sus); See Temperature and Oil Viscosity, page 9.060.1

Installation: No restrictions; See page 9.020.1

Cavity: VC10-4; See page 9.110.1

Cavity Tool: CT10-4XX; See page 8.600.1

Seal Kit: SK10-4X-MMM; See page 8.650.1

Cap Vent Seal: 6003117

SYMBOLS

USASI:

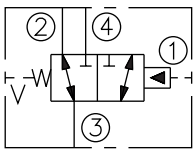

ISO:

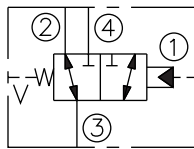

PERFORMANCE (Cartridge Only)

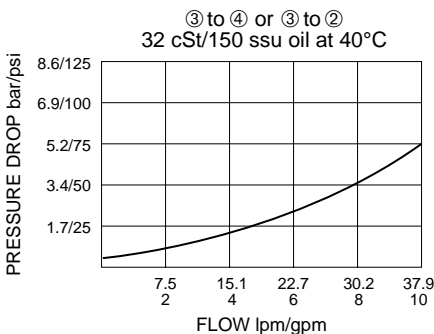

Note: This valve is designed with a dynamic oil-to-atmosphere seal in the vent section. Ambient conditions will cause this vent seal to degrade which will reduce the valve's cycle life. If this could cause a problem, we suggest that a non-vented model be selected. Consult factory for assistance.

