

# RV08-22 Relief, Direct-Acting, Differential Area

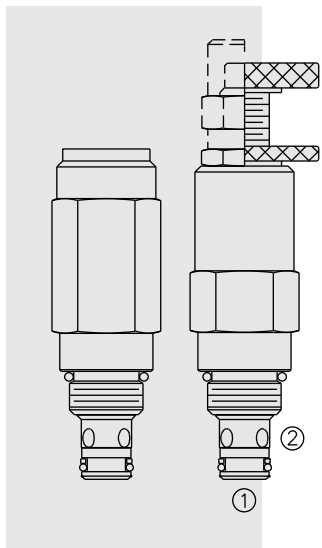

## ISO SYMBOL

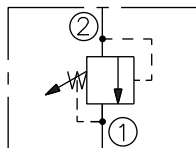

## PERFORMANCE (Cartridge Only)

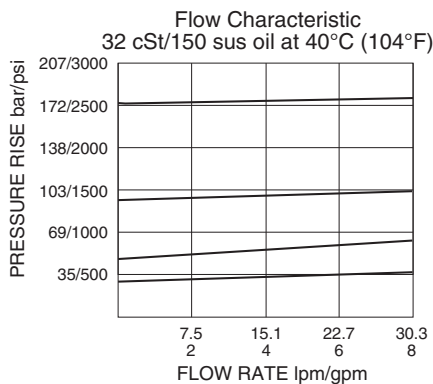

## DESCRIPTION

A screw-in, cartridge-style, direct-acting, differential area, poppet-type hydraulic relief valve for use as a pressure limiting device in more demanding hydraulic circuits, requiring low hysteresis and low internal leakage.

## OPERATION

The RV08-22 blocks flow from 2 to 1 until sufficient pressure is present at 2 to force the poppet from its seat.

The cartridge offers smooth transition in response to load changes in common hydraulic circuits.

**NOTE:** The RV08-22 may be used in cross-over relief applications (back pressure on 1) with the use of the "C" double back-up ring seal option. See Ordering Table.

## FEATURES

- Adjustments cannot be backed out of the valve.
- Variety of pressure adjustment options including non-adjustable factory pre-set.
- Adjustment options A, B, and C: positive stops prevent springs from going solid.
- Optional bi-directional pressure (requires bi-directional pressure seal option).
- Hardened poppet and cage for long life.
- Optional spring ranges to 248 bar (3600 psi).
- Smooth response to pressure surges.
- Industry common cavity.
- Compact size.

## RATINGS

**Pressure Rating:** 248 bar (3600 psi)

**Proof Pressure:** 496 bar (7200 psi)

**Burst Pressure:** 1038 bar (16168 psi)

**Flow Rating:** 30.3 lpm (8 gpm) at maximum pressure.

**Internal Leakage:** 0.25 ml/minute (5 drops/minute) max. to 85% of nominal setting

**Relief Pressure Setting Defined:** bar (psi) evident at 0.95 lpm (0.25 gpm)

**Reseat Pressure:** Nominal 90% of crack pressure

**Standard Spring Ranges:** 3.4 to 248.2 bar (50 to 3600 psi)

Shown in To Order section. Due to manufacturing tolerances, it may be possible to adjust the valve either lower or higher than the nominal ratings shown. **If the valve is adjusted beyond the recommended maximum pressure range for F and H style adjuster options, the valve may not open to relieve pressure.**

**Temperature:** -40 to 100°C (-40 to 212°F) with Buna N seals;

-26 to 204°C (-15 to 400°F) with fluorocarbon seals;

-54 to 107°C (-65 to 225°F) with polyurethane seals.

**Filtration:** See page 9.010.1

**Fluids:** Mineral-based or synthetics with lubricating properties at viscosities of

7.4 to 420 cSt (50 to 2000 sus); See Temperature and Oil Viscosity, page 9.060.1

**Installation:** No restrictions; See page 9.020.1

**Cavity:** VC08-2; See page 9.108.1

**Cavity Tool:** CT08-2XX; See page 8.600.1

**Seal Kit:** SK08-2X-T; or SK08-2X-M (for cross-over relief application); See page 8.650.1

# Poppet

# RV08-22

## DIMENSIONS

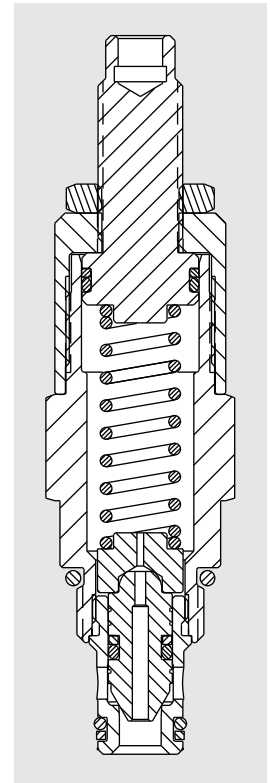
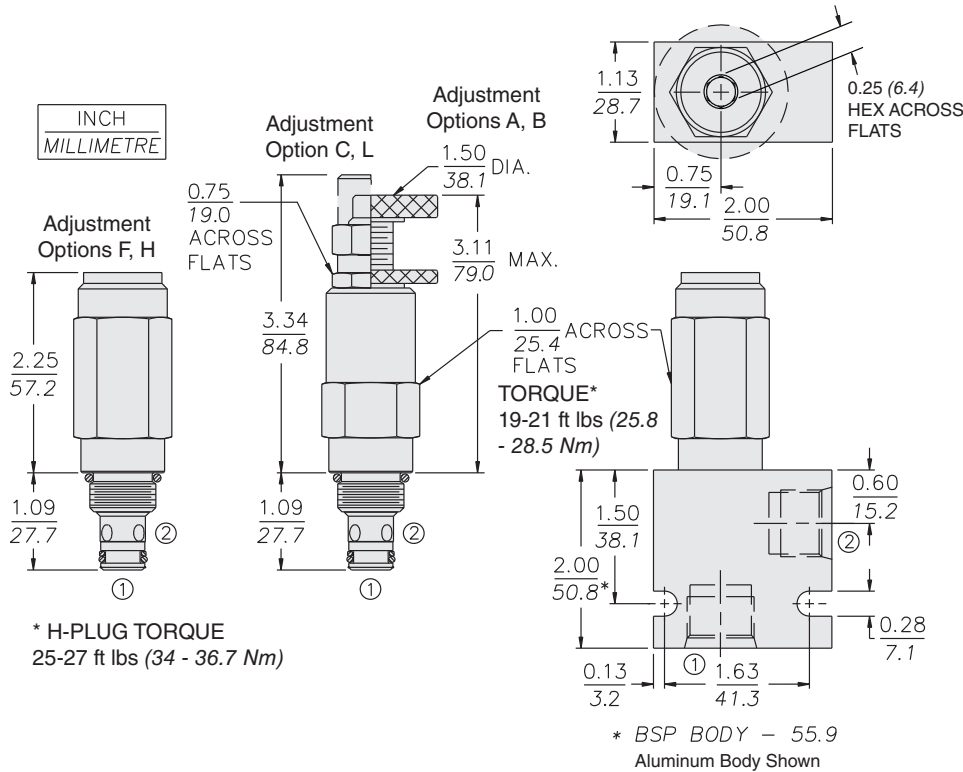

## MATERIALS

**Cartridge:** Weight: 0.16 kg. (0.35 lb.) to 0.22 (0.47 lb.) depending on adjustment option. Steel with hardened work surfaces. Zinc-plated exposed surfaces. Buna N O-rings and back-up standard. Anodized aluminum knob.

**Standard Ported Body:** Weight: 0.16 kg. (0.35 lbs.) Anodized high-strength aluminum alloy, rated to 207 bar (3000 psi). Ductile iron bodies available; dimensions may differ. See page 8.008.1

## TO ORDER

### RV08-22

- Adjustment Option**
- 1/4 in. Hex Allen Head **A**
  - 1-1/2 in. Dia. Alum. Knob **B**
  - Option A w/ Cover Cap **C**
  - Factory Preset Non-Adj. **F\***
  - Factory Preset Hidden Adj. **H\***
  - Option C w/ Lockwire Holes **L**

\* If the valve is adjusted beyond the recommended maximum pressure range for the F and H style adjuster options, the valve may not open to relieve system pressure.

- Porting**
- Cartridge Only **0**
  - SAE 4 **4T**
  - SAE 4 **4TD**
  - SAE 6 **6T**
  - SAE 6 **6TD**
  - SAE 8 **8T**
  - SAE 8 **8TD**
  - 1/4 in. BSP\* **2B**
  - 3/8 in. BSP\* **3B**
  - 3/8 in. BSP\* **3BD**

\*BSP Body; U.K. Mfr. Only

### Seals

- Pressure on P Only:**
- N** Buna N (Std.)
  - V** Fluorocarbon
  - P** Polyurethane
- Bidirectional Pressure:**
- NC** Buna N
  - VC** Fluorocarbon
  - PC** Polyurethane

Note: Polyurethane seals recommended for operation over 241 bar (3500 psi).

Note: When used in cross-over relief applications (back pressure on 1) be sure to specify the Bidirectional Pressure Seal Option and SK-08-2X-M Double-Back-Up Ring Seal Kit.

- Setting in bar**
- (Blank)<sup>†</sup> for Adjustable, or Specify, for example:  
**M150** 150 bar
- Setting in psi**
- (Blank)<sup>†</sup> for Adjustable, or Specify, for example:  
**35** 3500 psi

<sup>†</sup>Adjustable valves will be preset to approx. 50% of spring max.

### Spring Range

- 4** 3.4 to 27.6 bar (50 to 400 psi)
- 7** 6.9 to 48.3 bar (100 to 700 psi)
- 13** 10.3 to 89.6 bar (150 to 1300 psi)
- 26** 17.2 to 248.2 bar (250 to 3600 psi)

Note: Due to manufacturing tolerances, it may be possible to adjust the valve either lower or higher than the nominal ratings shown above.