

RV10-20 Relief, Direct-Acting Poppet

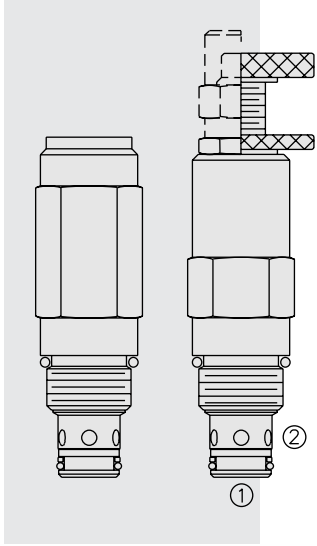

DESCRIPTION

A screw-in, cartridge-style, direct-acting, poppet-type, hydraulic relief valve intended for use as a pressure limiting device for common hydraulic circuit protection.

OPERATION

The **RV10-20** blocks flow from ① to ② until sufficient pressure is present at ① to force the poppet from its seat.

The cartridge offers fast response to load changes in typical hydraulic circuits requiring low internal leakage.

NOTE: The RV10-20 may be used in cross-over relief applications (back pressure on ②) with the use of the “C” double back-up ring seal option. See Ordering Table.

FEATURES

- Adjustments cannot be backed out of the valve.
- Adjustment options A, B, and C: positive stops prevent springs from going solid.
- Hardened poppet and cage for long life.
- Optional spring ranges to 228 bar (3300 psi).
- Rapid response to pressure surges.
- Industry common cavity.

RATINGS

Operating Pressure: 228 bar (3300 psi)

Flow: The Performance Chart illustrates flow handling capacity at maximum setting for each spring range option. Pressure rise will vary with spring (range) and with setting within range due to flow forces. Consult factory for specific flow characteristic values.

Internal Leakage: 0.25 cc/minute (5 drops/minute) max. to 80% of nominal setting

Crack (Set) Pressure Defined: bar (psi) evident at 0.95 lpm (0.25 gpm) attained

Reseat Pressure: Nominal 85% of crack pressure

Standard Spring Ranges: Due to manufacturing tolerances, it may be possible to adjust the valve either lower or higher than the nominal ratings shown below.

Spring Model Code	Nominal Factory Rating	Maximum Solid Adjustment
6	3.45 – 41.38 bar (50 – 600 psi)	55.17 bar (800 psi)
12	10.34 – 82.76 bar (150 – 1200 psi)	110.34 bar (1600 psi)
23	17.24 – 158.62 bar (250 – 2300 psi)	200 bar (2900 psi)
33	17.24 – 227.59 bar (250 – 3300 psi)	255.17 bar (3700 psi)

Temperature: -40 to 120°C

Filtration: See page 9.010.1

Fluids: Mineral-based or synthetics with lubricating properties at viscosities of 7.4 to 420 cSt (50 to 2000 sus); See Temperature and Oil Viscosity, page 9.060.1

Installation: No restrictions; See page 9.020.1

Cavity: VC10-2; See page 9.110.1

Cavity Tool: CT10-2XX; See page 8.600.1

Seal Kit: SK10-2X-B; See page 8.650.1; SK10-2X-M (for cross-over relief application)

SYMBOLS

USAS/ISO:

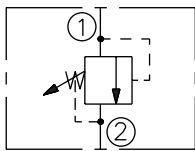

PERFORMANCE (Cartridge Only)

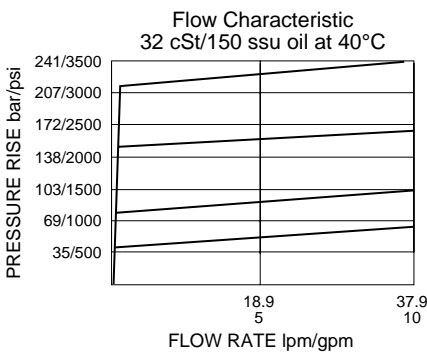

DIMENSIONS

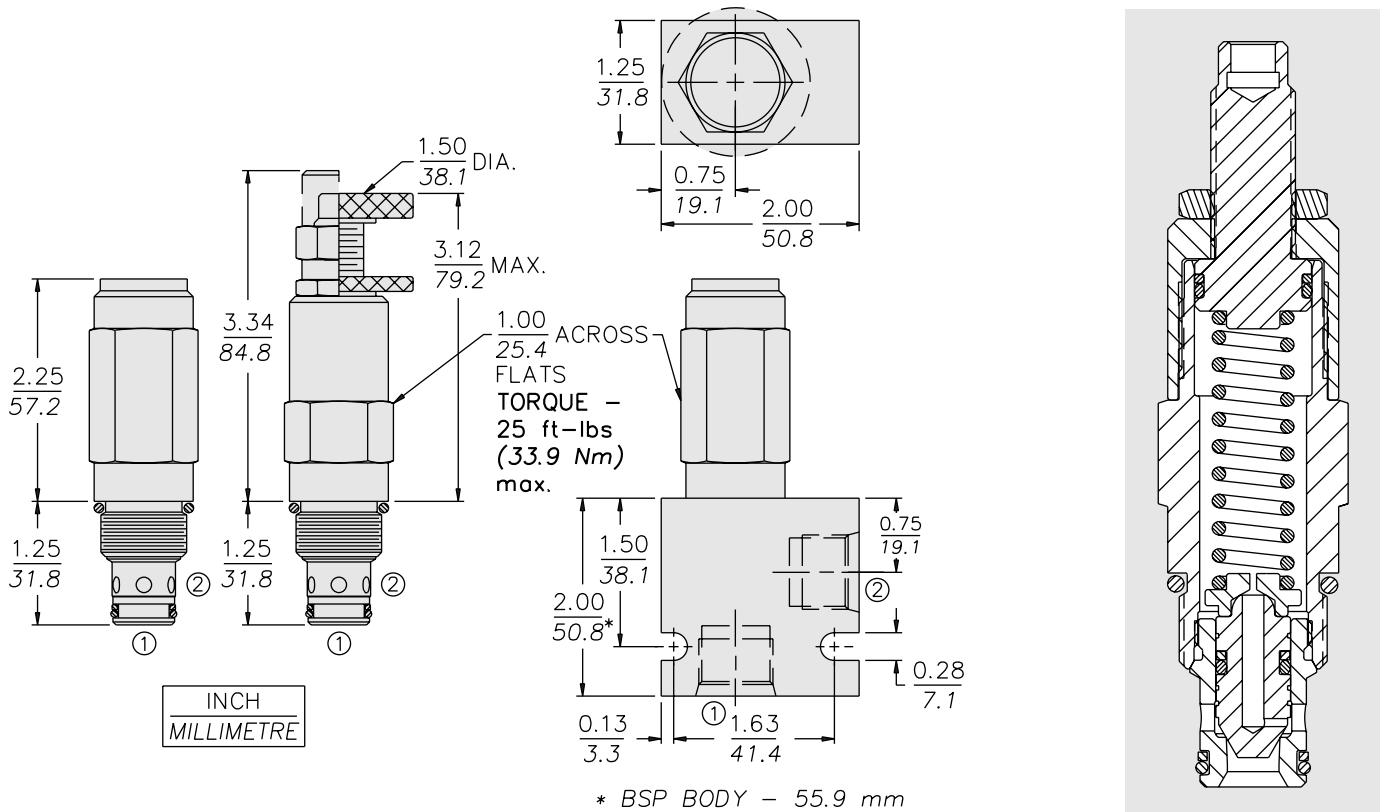

MATERIALS

Cartridge: Weight: 0.23 kg. (0.50 lbs.)
 Steel with hardened work surfaces.
 Zinc-plated exposed surfaces.
 Buna N O-rings and polyester elastomer back-up standard;
 Anodized aluminum knobs.

Standard Ported Body: Weight: 0.16 kg. (0.35 lbs.) Anodized high-strength 6061 T6 aluminum alloy, rated to 207 bar (3000 psi). Ductile iron bodies available; dimensions may differ. See page 8.010.1

TO ORDER

RV10-20

- Adjustment Option**
- 1/4 in. Hex Allen Head **A**
 - 1-1/2 in. Dia. Alum. Knob **B**
 - Option A w/ Cover Cap **C**
 - Factory Preset Non-Adj. **F**
 - Factory Preset Hidden Adj. **H**
 - Option C w/ Lockwire Holes **L**

- Porting**
- Cartridge Only **0**
 - SAE 6 **6T**
 - SAE 8 **8T**
 - 1/4 in. BSP* **2B**
 - 3/8 in. BSP* **3B**
 - 1/2 in. BSP* **4B**

*BSP Body; U.K. Mfr. Only

- Seals**
- Pressure on P Only:**
 - N** Buna N (Std.)
 - V** Fluorocarbon
 - Bidirectional Pressure:**
 - NC** Buna N
 - VC** Fluorocarbon

- Setting in bar[†]**
- (Blank) for Adjustable, or Specify, for example:
- M25** 25 bar
 - M100** 100 bar
- Setting in psi[†]**
- (Blank) for Adjustable, or Specify, for example:
- 9.0** 900 psi
 - 23.5** 2350 psi

- Spring Range**
- 6** 3.45 to 41.38 bar (50 to 600 psi)
 - 12** 10.34 to 82.76 bar (150 to 1200 psi)
 - 23** 17.24 to 158.62 bar (250 to 2300 psi)
 - 33** 17.24 to 227.59 bar (250 to 3300 psi)

[†]Adjustable valves will be preset to approx. 50% of spring max.