

SV10-41 Spool, 4-Way, 2-Position

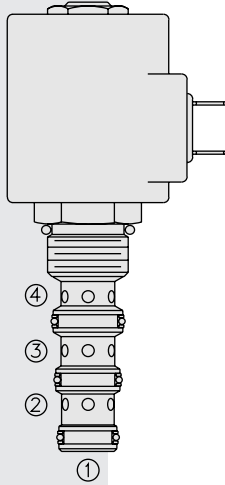

SYMBOLS

USAS/ISO:

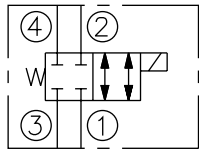

PERFORMANCE (Cartridge Only)

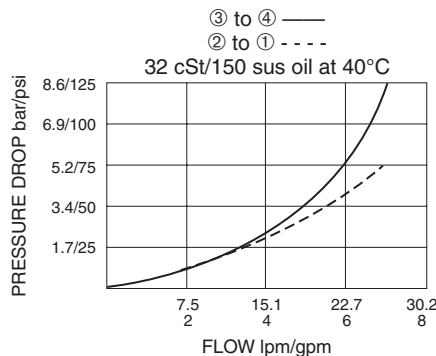

DESCRIPTION

A solenoid-operated, 4-way, 2-position, direct-acting, spool-type, screw-in hydraulic cartridge valve.

OPERATION

When de-energized, the **SV10-41** blocks flow to all ports.

When energized, the spool shifts to open flow between ③ and ④, as well as from ② to ①.

Operation of Manual Override Option: To override, push button in and twist counterclockwise 180°. The internal spring will push the button out. In this position, the valve may be only partially shifted. To assure full override shift, pull the button out to its fullest extension and hold it in this position.

To return to normal valve function, push button in, twist clockwise 180° and release. Override will be detented in this position.

FEATURES

- Continuous-duty rated solenoid.
- Hardened precision spool and cage for long life.
- Optional coil voltages and terminations.
- Efficient wet-armature construction.
- All ports may be fully pressurized.
- Cartridges are voltage interchangeable.
- Manual override option.
- Optional waterproof E-Coils rated up to IP69K.
- Unitized, molded coil design.
- Industry common cavity.

RATINGS

Operating Pressure: 207 bar (3000 psi)

Proof Pressure: 350 bar (5075 psi)

Flow: See Performance Chart

Internal Leakage: 82 cc/minute (5 cu. in./minute) max. at 207 bar (3000 psi)

Temperature: -40 to 120 °C with standard Buna seals

Coil Duty Rating: Continuous from 85% to 115% of nominal voltage

Response Time: First indication of change of state with 100% voltage supplied at 80% of nominal flow rating: Energized: 45 ms; De-energized: 50 ms

Initial Coil Current Draw at 20 °C: Standard Coil: 1.67 A at 12 Vdc; 0.18 A at 115 Vac (full wave rectified).
E-Coil: 1.7 A at 12 Vdc; 0.85 A at 24 Vdc

Minimum Pull-in Voltage: 85% of nominal at 207 bar (3000 psi)

Filtration: See page 9.010.1

Fluids: Mineral-based or synthetics with lubricating properties at viscosities of 7.4 to 420 cSt (50 to 2000 sus); See Temperature and Oil Viscosity, page 9.060.1

Installation: No restrictions; See page 9.020.1

Cavity: VC10-4; See page 9.110.1

Cavity Tool: CT10-4XX; See page 8.600.1

Seal Kit: SK10-4X-MMM; See page 8.650.1

Coil Nut: Part No. 7004400;

For E-coils manufactured prior to 1-1-04, see page 3.400.1 for coil nut info.

DIMENSIONS

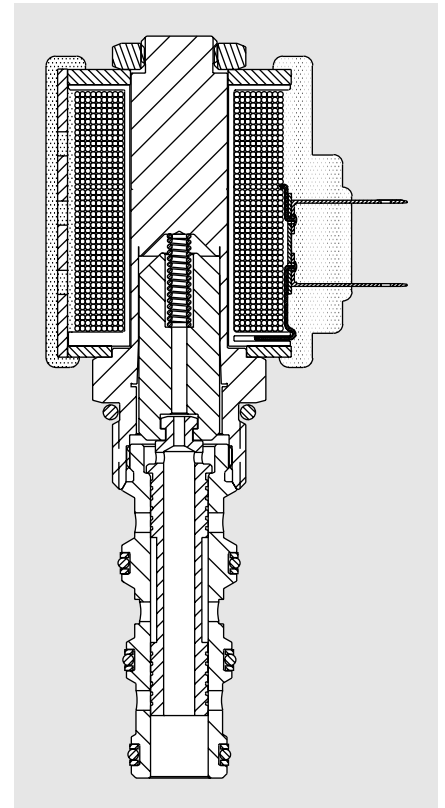
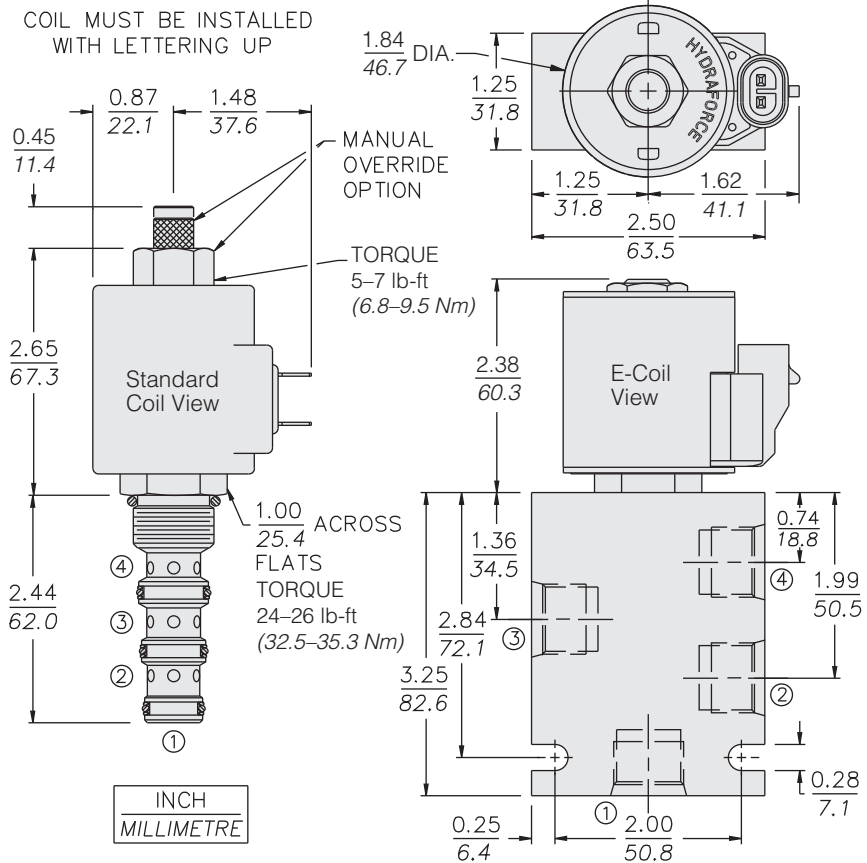

MATERIALS

Cartridge: Weight: 0.20 kg (0.45 lb); Steel with hardened work surfaces. Zinc-plated exposed surfaces. Buna N O-rings and polyester elastomer back-up standard.

Standard Ported Body: Weight: 0.36 kg (0.80 lb); Anodized high-strength 6061 T6 aluminum alloy, rated to 207 bar (3000 psi). Ductile iron bodies available; dimensions may differ. See page 8.010.1.

Standard Coil: Weight: 0.27 kg (0.60 lb); Unitized thermoplastic encapsulated, Class H high temperature magnet wire. See page 3.200.1.

E-Coil: Weight: 0.41 kg (0.9 lb); Fully encapsulated with rugged external metal shell. Rated up to IP69K with integral connectors. **Note: See page 3.400.1 for all E-Coil retrofit applications.**

TO ORDER

SV10-41

Option	Voltage	Termination (Vdc)
None (Blank)	Std. Coil	Std. Coil
Manual Override M	0 Less Coil**	DS Dual Spades
Manual Override Y	10 10 Vdc†	DG DIN 43650
Manual Override J	12 12 Vdc	DL Leadwires (2)
For Manual Override options see page 1.001.1	24 24 Vdc	DL/W Leads w/Weatherpak® Connectors
	36 36 Vdc	DR Deutsch DT04-2P
	48 48 Vdc	
	24 24 Vac	Termination (Vac)
Porting	115 115 Vac	Std. Coil
Cartridge Only 0	230 230 Vac	AG DIN 43650
SAE 8 8T		AP 1/2 in. Conduit
	**Includes Std. Coil Nut	Termination (Vdc)
	† DS, DW or DL terminations only.	E-Coil
		ER Deutsch DT04-2P (IP69K Rated)
Seals	E-Coil	EY Metri-Pack® 150 (IP69K Rated)
Buna N (Std.) N	10 10 Vdc	
Fluorocarbon V	12 12 Vdc	
	20 20 Vdc	
	24 24 Vdc	

Coils with internal diode are available. Consult factory.