

SV10-47C Spool, 4-Way, 3-Position, Closed Center

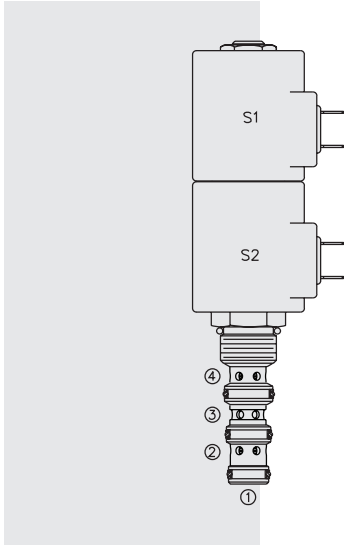

DESCRIPTION

A solenoid-operated, 4-way, 3-position, direct-acting, spool-type, closed center, screw-in hydraulic cartridge valve.

OPERATION

When de-energized, the SV10-47C blocks flow to all ports. When coil #1 is energized, flow is allowed from 3 to 4, and from 2 to 1. When coil #2 is energized, flow is allowed from 3 to 2, and from 4 to 1. In circuits where work port flows are unequal due to cylinder ratios, the higher return flow should be directed to port 2. **NOTE: While 1 may be fully pressurized, it is not intended for use as the valve's inlet.**

Operation of Manual Override Option: To override, push the knurled button to activate the coil #2 (S2) function, or pull the knob to activate the coil #1 (S1) function.

FEATURES

- Optional coil voltages and terminations.
- Efficient wet-armature construction.
- All ports may be fully pressurized.
- Cartridges are voltage interchangeable.
- Hardened precision spool and cage for long life.

ISO SYMBOL

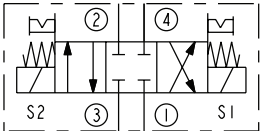

RATINGS

Operating Pressure: 250 bar (3625 psi); **Proof Pressure:** 344 bar (5000 psi)

Burst Pressure: 779 bar (11,300 psi)

Flow: 23 lpm (6 gpm) max.

Internal Leakage: 328 ml/minute (20 cu. in./minute) max. at 207 bar (3000 psi)

Temperature: -40 to 100 °C (-40 to 212 °F) with standard Buna seals; -26 to 204 °C (-15 to 400 °F) with fluorocarbon seals; -54 to 107 °C (-65 to 225 °F) with polyurethane seals

Coil Duty Rating: Continuous from 85% to 115% of nominal voltage

Initial Coil Current Draw at 20° C: Standard Coil: 1.67 A at 12 Vdc; 0.18 A at 115 Vac (full wave rectified).

E-Coil: 1.7 A at 12 Vdc; 0.85 A at 24 Vdc

Minimum Pull-in Voltage: 85% of nominal at 207 bar (3000 psi)

Filtration: See page 9.010.1

Fluids: Mineral-based or synthetics with lubricating properties at viscosities of 7.4 to 420 cSt (50 to 2000 sus); See Temperature and Oil Viscosity, page 9.060.1

Installation: No restrictions; See page 9.020.1

Cavity: VC10-4; See page 9.110.1; **Cavity Tool:** CT10-4XX; See page 8.600.1

Seal Kit: SK10-4X-MMM; See page 8.650.1

Coil Nut: Part No. 7004400; **Manual Override Coil Nut:** Part No. 4528180

Coil Spacer: Std. D-Coil Spacer Part No. 7009286; E-Coil Spacer Part No. 4539700; If cartridge is ordered "Less Coil," D-Coil spacer will be provided unless an E is specified in the Coil Termination To Order section.

PERFORMANCE (Cartridge Only)

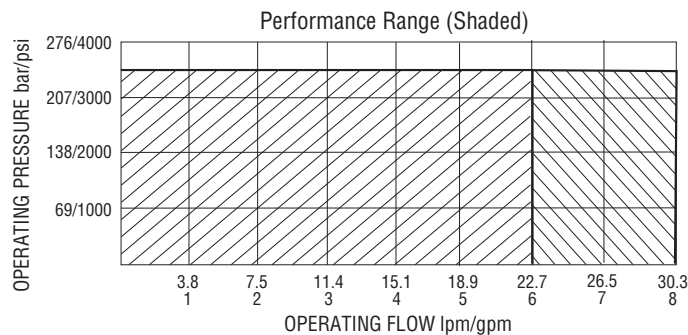
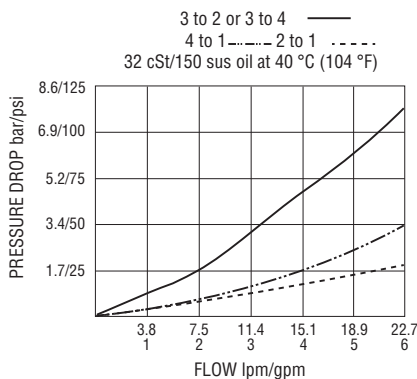

NOTE: Consult factory if operating flow above 22.7 lpm (6 gpm) is with oil viscosity over 420 cSt and/or valve is operated continuously (100% duty cycle).

DIMENSIONS

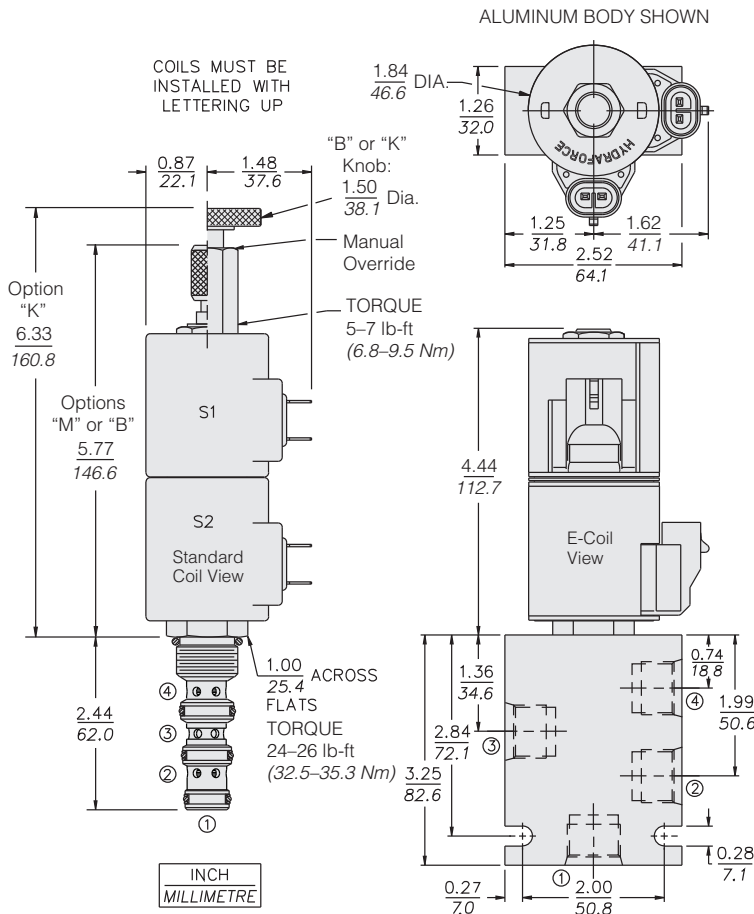

MATERIALS

Cartridge: Weight: 0.25 kg (0.55 lb); Steel with hardened work surfaces. Zinc-plated exposed surfaces; Buna N O-rings and back-ups standard.

Standard Ported Body: Weight: 0.36 kg (0.80 lb); Anodized high-strength aluminum alloy, rated to 207 bar (3000 psi); Ductile iron bodies available; dimensions may differ. See page 8.010.1.

Standard Coil: Weight each: 0.27 kg (0.60 lb); Unitized thermoplastic encapsulated, Class H high temperature magnet wire. See page 3.200.1

E-Coil: Weight: 0.41 kg (0.9 lb); Perfect wound, fully encapsulated with rugged external metal shell; Rated up to IP69K with integral connectors. See page 3.400.1

TO ORDER

