

SV12-34 Spool, 3-Way

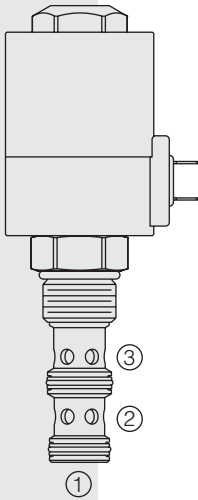

DESCRIPTION

A solenoid-operated, three-way, direct-acting spool-type, screw-in hydraulic cartridge valve.

OPERATION

When de-energized, the **SV12-34** allows flow between ② and ①, while blocking flow at ③. When energized, the spool shifts to allow flow between ② and ③, while blocking flow at ①.

FEATURES

- Continuous-duty rated solenoid.
- Hardened spool and cage for long life.
- Optional coil voltages and terminations.
- All ports may be fully pressurized.
- Heavy-duty waterproof E-Coils rated up to IP69K.

RATINGS

Operating Pressure: 240 bar (3500 psi) max.

Flow: See Performance Chart

Leakage: 410 cc/minute (25 cu. in./minute) at 240 bar (3500 psi)

Temperature: -40 to 120 °C with Buna N seals

Coil Duty Rating: See Chart

Response Time: Pull-In: 100 ms Drop-Out: 100 msec

Initial Coil Current Draw at 20 °C: 2.8 A at 12 Vdc

Filtration: See page 9.010.1

Fluids: Mineral-based or synthetics with lubricating properties at viscosities of 7.4 to 420 cSt (50 to 2000 sus); See Temperature and Oil Viscosity, page 9.060.1

Installation: No restrictions; See page 9.020.1

Cavity: VC12-3; See page 9.112.1

Cavity Tool: CT12-3XX; See page 8.600.1

Seal Kit: SK12-3X-MM; See page 8.650.1

E-Coil Nut: Part No. 7085180

SYMBOLS

USAS/ISO:

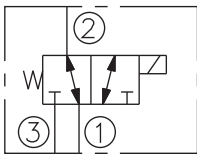

PERFORMANCE (Cartridge Only)

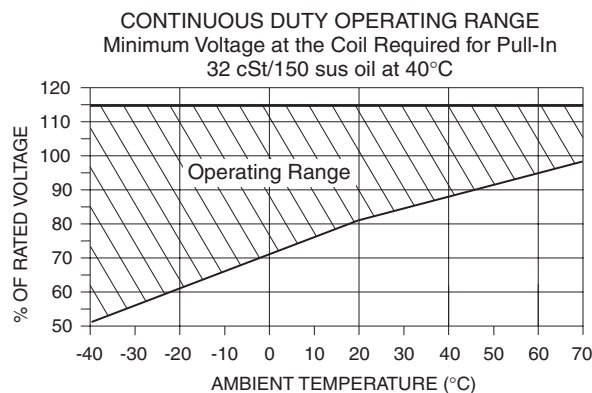
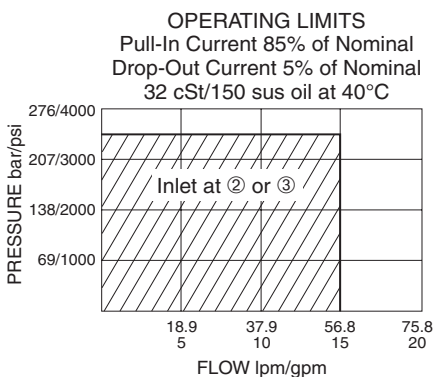
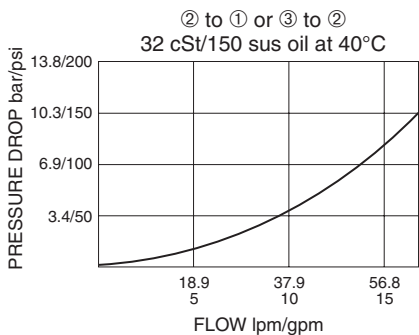

DIMENSIONS

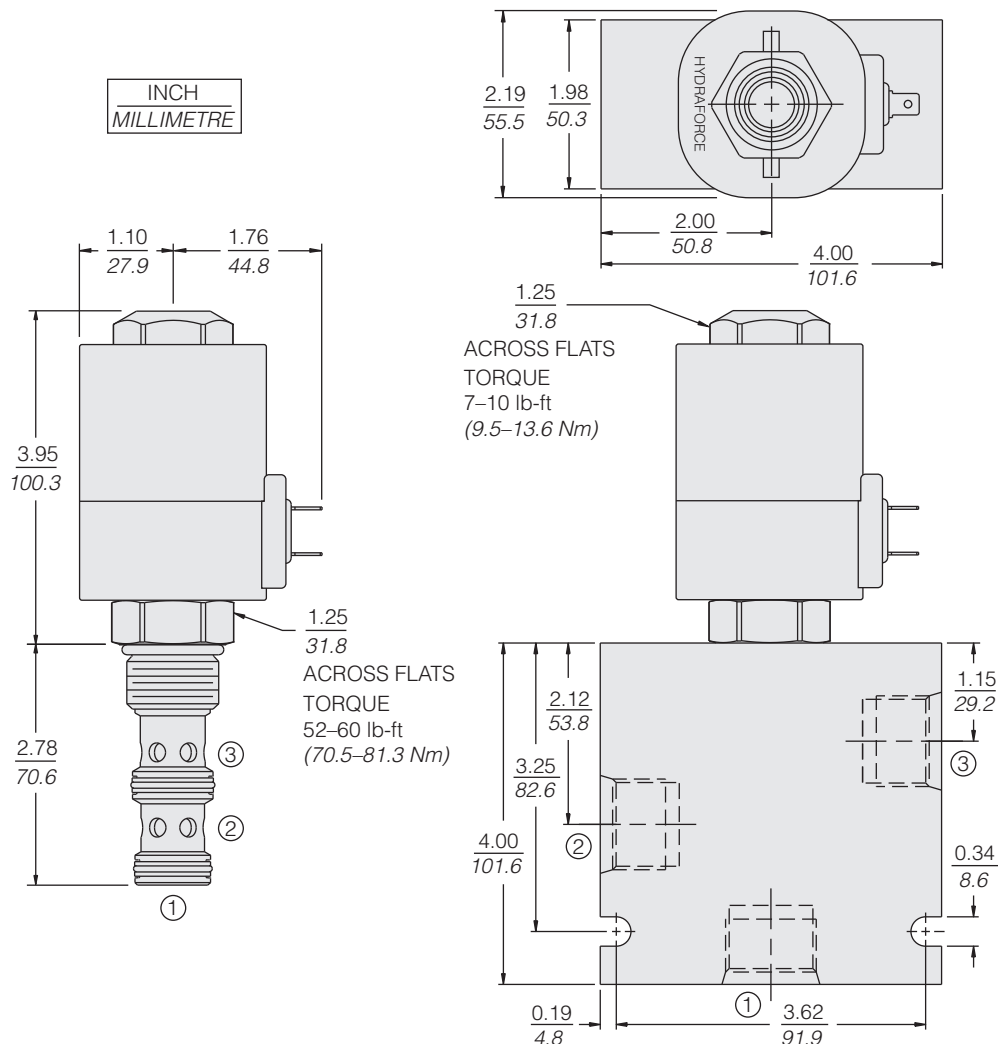

MATERIALS

Cartridge: Weight: 0.29 kg (0.65 lb)
Steel with hardened work surfaces.
Zinc-plated exposed surfaces.
Buna N O-rings and TFE back-ups standard.

Standard Ported Body: Weight: 0.98 kg (2.15 lb)
Anodized high-strength 6061 T6 aluminum alloy, rated to 207 bar (3000 psi). Ductile iron bodies available; dimensions may differ. See page 8.012.1.

E-Coil: Weight: 1.36 kg (3.0 lb)
Fully encapsulated with rugged external metal shell.

Rated up to IP69K with integral connectors. See page 3.400.1.

TO ORDER

SV12-34		-	-	-	-	-	-
Option	(Blank)						
None							
Manual Override without Knob	P						
Manual Override with Knob	K						
Porting							
Cartridge Only	0						
SAE 8	8T						
SAE 10	10T						
SAE 12	12T						
1/2 in. BSP*	4B						
3/4 in. BSP*	6B						
Seals							
N Buna N (Std.)							
V Fluorocarbon							
Voltage							
0 Less Coil							
12 12 Vdc							
24 24 Vdc							
Terminations (Vdc)							
EL Leadwires (2), IP65 Rated							
ES Dual Spades, IP65 Rated							
EG DIN 43650, IP65 Rated							
EW Leads w/Weather-Pack® Connector, IP65 Rated							
EY Metri-Pack® 150 Connector, IP69K Rated							
Coils with internal diode are available. Consult factory.							
Other coil voltages may be available for OEM applications. Consult factory.							